



THE TRADITIONAL
TOOLS GROUP INC.



TTTG NEWSLETTER NO. 27
FEBRUARY 1996



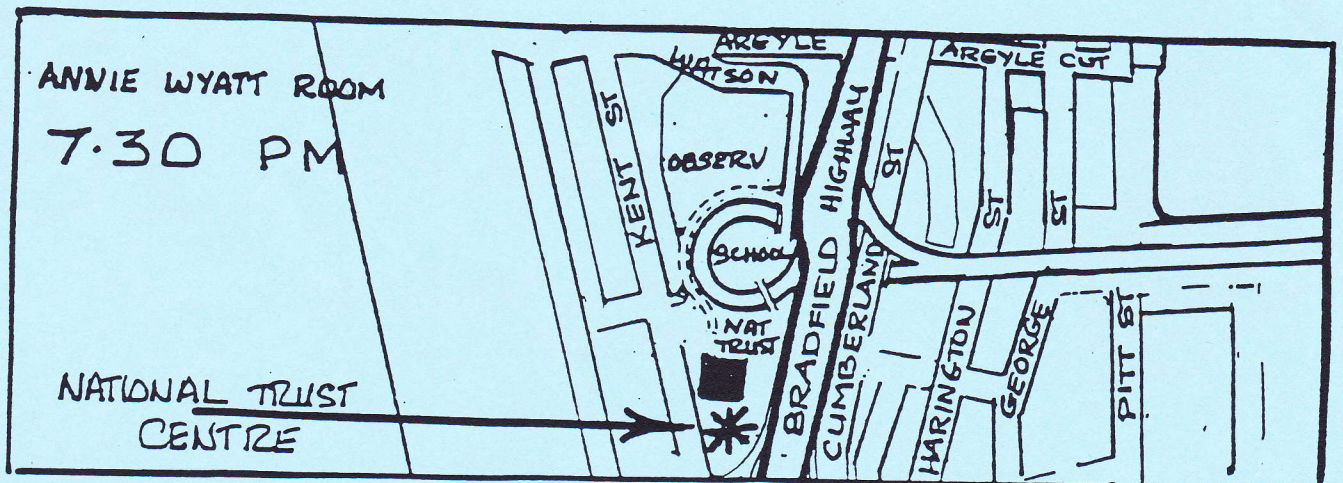

OUR NEW POSTAL ADDRESS

The Secretary
T.T.T.G. Inc.
P.O. Box 240
GROSVENOR PLACE
SYDNEY NSW 2000

NEXT MEETING-TUESDAY FEBRUARY 13TH

AT THE ANNIE WYATT ROOM, NATIONAL TRUST CENTRE, OBSERVATORY HILL
COMMENCING AT 7.30PM SHARP

PROGRAMME.

1. WET PLASTERING. MARK GOODCHILD WILL TRACE THE HISTORY AND EXPLORE THE TECHNIQUES OF THIS TRADE WHICH HAS BECOME ALL TOO RARE IN THE MODERN APPROACH TO BUILDING. MARK IS A MASTER PLASTERER WHOSE CRAFT SPANS THE SPECTRUM FROM FUNCTIONAL TO DECORATIVE THROUGH TO SCULPTURAL. THIS PROMISES TO BE A FASCINATING EVENING.
2. TOOL SWAP. ANY TRADITIONAL PLASTERING TOOLS FOR SALE OR SWAP?
3. FRED MURRELL'S "WOTSIT" YOUR CHANCE TO BEAT THE EXPERTS!
4. LIBRARY TABLE. RICK MITCHELL IS OUR NEW LIBRARIAN.
5. SUPPER BY MARIO DATO.

TTTG Inc.

THE TRADITIONAL TOOLS GROUP

TTTG NEWSLETTER NO.27
FEBRUARY 1996

CONTENTS

REGULAR FEATURES:

Editor's Notes Bob Crosbie
Patents
Collector's Page
Favourite Tools
Previous Meeting

ARTICLES:

Last Marples Wood Planes
Emir: Last English Wood Plan Maker
Stormont Archer: Last English Plane Blade Maker
Exhibition Hyde Park Barracks Museum
Researching Tradesmen's Lives

Next Meeting

Cover: *Pawnbrokers from Hogarth's Gin Lane*

© Copyright. 1996

Any opinions expressed are those of the contributor.

EDITOR'S NOTES:

Our last Committee Meeting was an important event. A new librarian has emerged! TTTG's Librarian and Committee member is Rick Mitchell.

Sid Bailey, our previous Librarian, laid the groundwork for a comprehensive collection of technology related books, old catalogues and articles. Rick is keen to build on this foundation. Any donations to the Library will be eagerly accepted. The system of "Loans" will be re-introduced as soon as the TTTG Library is catalogued.

The editor received some criticism at the previous Committee Meeting relating to the tone of some of the material in previous newsletters. Sensing a chance to be deposed I suggested no confidence motion be passed against the Editor. Sadly no-one proposed such a motion.

Admonished I have tried to save my credibility by introducing a new regular feature Collector's Page and by writing a series of articles on the demise of the wooden plane. Though personal I think they will interest the keenest plane buff.

By the time you receive this newsletter the annual tool sale will be only weeks away. For ten years this has been the big event for tool users and collectors in Sydney. This year's sale promises to be better than ever.

TTTG has assisted in presenting a "showcase" of early nineteenth century tools at the Hyde Park Barracks Museum. If you are in Macquarie Street why not drop into the Barracks and view the tools and perhaps have a look at the other exhibitions.

FAVOURITE TOOLS

There have been no submissions for this column. Does this mean a lack of interest? Perhaps the collectors among us can contribute to this column. So far the discussions have been about mundane tools.

If you want to air your views on Preston or Stanley or any upmarket collector's items, here is your chance.

The column will not appear in the next newsletter if no submissions are received.

PREVIOUS MEETING

Kevin Little presented a fine and humorous talk on Stained and Leadlight Glass.

The technical aspects of this trade were covered in a masterly fashion. Kevin literally ranged from the stone age to yesterday. The problems faced in restoration work, both technical and cultural, were discussed in a precise, insightful manner.

The talk was recorded and in future such talks will be available for loan from the Library.

TTTG wishes to thank Kevin Little for his generosity in sharing his knowledge with TTTG members.

COLLECTOR'S PAGE

Since TTTG was founded the perennial question arises: "What's it worth?". Valuing tools is a mare's nest and most of the Committee wisely evade such questions.

Despite the problems it has to be admitted that many members are looking for some indication of price.

The newsletter committee has decided to "trial" reprinting prices from overseas dealers. This may provide some useful comparisons. Even so price is relative and usually related to circumstance.

The list below is from Bristol Design's latest price list. Copies of Bristol Design's price list will soon be available for loan from the TTTG Library.

page 8	Bristol Design	list 50
50.9 TRADITIONAL WOOD FILLED METAL PLANES - THE SMALLER ONES		
50.9.1	A cast steel shoulder plane, 8" long by 1 1/8" wide. Quite a nice shape to this user made plane. but he didn't know how to finish the rosewood infill.	G \$112
50.9.2	A cast steel rosewood filled rabbet plane, 8" long by 5/8" wide.	G \$88
50.9.3	A gunmetal shoulder plane, 8" long by 1" wide. This plane is nice and clean with a well finished rosewood inlay.	G+ \$179
50.9.4	A good quality cast steel shoulder plane. 8" long by 1 1/2" wide with good ebony infill.	G+ \$159
50.9.5	A cast steel shoulder plane, 8" long by 1 1/2" wide. This plane by SLATER has a mahogany infill.	G \$110
50.9.6	A cast steel shoulder plane overstuffed in rosewood with a skew mouth. 8" by 1 1/4".	G \$110
50.9.7	An Irish pattern chariot plane, 6" long by 2" wide. mahogany wedge. *V*	G \$89
50.9.8	An Irish pattern chariot plane with oak wedge and front bun, skew mouthed. 6 1/2" long by 2" wide.	G \$99
50.9.9	A traditional shaped chariot plane with a nice chunky rosewood wedge. Plane 5" by 2".	G+ \$98
50.9.10	A similar chariot plane with beech wedge which looks as if it once had a front bun. Plane 5" by 2".	G \$89
50.9.11	A small cast steel shoulder plane, 5 1/2" long by 5/8" wide with mahogany infill. A few flaws in the casting *V*	G \$82
50.9.12	A steel soled gunmetal shoulder plane, 5" long by 3/8" wide. *V*	G \$93
50.9.13	A small bullnose plane which looks as if it has been cut from the solid. Rosewood wedge. Plane 3" by 1/2".	G+ \$80

LAST MARPLES WOOD PLANES

Marples are recorded by Goodman as among the last of the U.K. wood plane manufacturers. The letter reproduced below documents the end of plane production by marples.



MARPLES "SHAMROCK" BRAND TOOLS

CABLES: MARPLES, SHEFFIELD, 1

YOUR REF.

OUR REF. AOCF/KMH

WILLIAM MARPLES & SONS LTD.,

TOOL MANUFACTURERS

HIBERNIA WORKS,

SHEFFIELD, 1,

ENGLAND.

26th March 1969

Mr. R.A. Crosbie
140 Wicks Road
North Ryde 2113
N.S.W.
AUSTRALIA

Dear Sir,

We have your letter undated concerning Beechwood Moulding Planes etc.

Ever since this company was founded in 1828 we have been manufacturers of wooden planes, both bench planes and moulding, Sash Fillister, Plough etc. We regret however, that owing to the ~~very~~ very small demand this trade has entirely died out in favour of the more up to date metal planes, coupled with modern production methods. We discontinued the manufacture of our wood planes about five years ago.

All we can suggest is that you contact :

Messrs Emmerich (Berlon) Ltd.,
Wotton Road,
Ashford
Kent, England.

who do still manufacture a few of the more regular patterns of moulding planes. We are sending your letter on to them together with a copy of our reply, and trust you may be fortunate in obtaining your requirements.

Yours faithfully,
WILLIAM MARPLES & SONS LIMITED

EMIR: LAST ENGLISH WOOD PLANE MAKER

Before I received the letter from Marples I had purchased tools from "Emir". The firm sent me their price list of planes. This list may resurface one day! I think I bought "Emir" tools in 1968 or 1969.

The range was extensive and I did purchase some of the planes on offer. The quality was variable. The bench planes were of reasonable quality, though fairly rough in the finish. The planes were entirely machine made.

I still have an Emir tothing plane which is very well made; perhaps I re-worked the chamfers! Admittedly the beech in the planes was a little soft.

The moulding planes I bought were disappointing. Most were of German pattern, machine made and coated in nitro cellulose. However some were half English, half German in design. The ogee and ovals had no spring. I still have most of these moulding planes -- any offers?

I did not want to risk buying large expensive tools by mail. So I resisted the temptation to buy the Plough and Sash Fillister. Later I saw many Emir ploughs and fillisters when I was teaching in NSW high schools. They had screw stems, and horn beam soles on the fillisters. The quality was very poor. Every one I saw had stripped nuts and other damage. I have a set of the plough irons and a plough skate, depth stop etc. The irons are not tapered and the skate is thicker than the smallest iron.

Emir's price list had badgers and other "special" planes but I have not seen any of these. Other tools listed were plasterers' tools, benches etc. Emir is still in business. When I received the Emir list it was dated 1966 and stamped "discontinued". I believe Emir was the last United Kingdom makers of wood planes. The planes I purchased were obviously the "last of the line" in more ways than one.

Despite the quality of the wooden components many of the planes had excellent irons (blades). These were stamped "Lighthouse" or "Stormont Archer" so I wrote to Emir to try and buy some irons. The letter below documents the end of plane iron (wood type) production in the U.K.

Footnote.

I think it is constructive to look at the establishment date of "EMIR" in the UK and speculate on the origin of this firm.

According to Goodman, Frederick William Emmerich started making planes in Bermondsey, London in about 1935. His planes were very European in appearance, fairly devoid of chamfers and decorative features as described above. The Germanic name, type of plane and date suggests that Emmerich may have been one of the many German Jews who were fleeing the persecution of their Race in Germany at that time.

In 1946, we find that Emmerich formed EMMERICH(BERLON) Ltd. and adopted the trademark "EMIR". I speculate that this corresponds with the end of the War and Emmerich was able to reestablish his business in Berlin as well as London, hence the "BERLON" inclusion in the Company name. Today ECE Primus planes are still manufactured in Germany by E.C.Emmerich and I have a photograph of E.C.Emmerich published in a trade catalogue in 1982. He appears to be a man of about 40 years old; could he be Frederick's son, born during the War and now carrying on the business in Germany? Can any members shed any light on this little mystery?

Mike Williams.

STORMONT ARCHER: LAST ENGLISH WOOD PLANE IRON MAKER.

Through Buck & Ryan in London I located Stormont Archer. Some time in 1968? I wrote to Stormont Archer in Sheffield.

I received a small catalogue from Stormont Archer. In due course this may resurface! They listed all types of joiner's tools. Plane irons, chisels, saws etc.

I purchased some of the plane irons. These proved to be excellent. I still have a few spare irons left. The two and half inch was very thick and the temper superb. The tothing irons were also very good.

This gave me the confidence to order some chisels. These were very poor, badly finished, soft, low quality handles.

I suspect the plane irons were old stock. Stormont Archer's trademark was "Lighthouse" and they clearly were the last suppliers to Emir. The cessation of production by Marples must have allowed "Emir" and Stormont Archer to keep up production for 2 or 3 years until the swinging sixties killed off traditional tool production.

If my Stormont Archer, Emir, Buck & Ryan catalogues have survived and can be found I will reprint extracts in future newsletters.

Any TTTG members with knowledge of these, and other, firms are encouraged to contact the Editor.



EMMERICH (BERLON) LTD. Manufacturers of Wooden Tools, Chests and Benches

Telephone: ASHFORD (Kent) 22684-5-6

WOTTON ROAD, ASHFORD, KENT, ENGLAND. Date 3rd November 1970

R.A. Crosbie, Esq.,
140 Wicks Road,
North Ryde 2113,
N.S.W.,
Australia.

Dear Sir,

We thank you for your enquiry of the 26th October 1970, but regret to advise you that we can no longer supply Plane Irons as the Sheffield Manufacturers have ceased to manufacture them.

With our apologies for not being able to assist you in this matter.

Yours faithfully,
For EMMERICH (BERLON) LIMITED

J.C. WALL
DIRECTOR

PATENTS

Following on from the article on Starrett last issue, readers may be interested in a completely different approach taken by Preston to the problem of producing a "combination" square. The illustration below is from the Preston 1909 Catalogue, reprinted by Astragal Press in 1991. The Registered Design Number shown on the device was issued in 1909 so presumably this was a new product issued that year.

PRESTON REGISTERED Depthing Gauge, Mitre and Try Square

No. 65.

DRAWING IS FULL
SIZE OF HEAD.

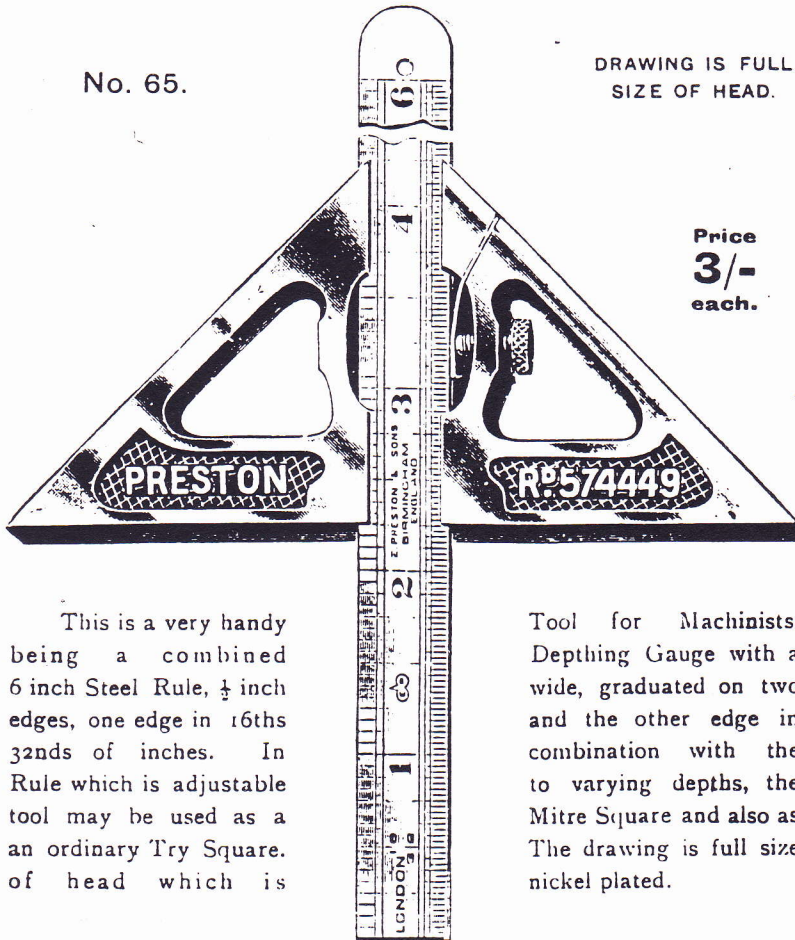

Price
3/-
each.

This is a very handy being a combined 6 inch Steel Rule, $\frac{1}{4}$ inch edges, one edge in 16ths 32nds of inches. In Rule which is adjustable tool may be used as a an ordinary Try Square. of head which is

Tool for Machinists, Depthing Gauge with a wide, graduated on two and the other edge in combination with the to varying depths, the Mitre Square and also The drawing is full size nickel plated.

Manufacturers—

EDWARD PRESTON & SONS, Ltd.,

WHITTALL WORKS, BIRMINGHAM, Eng.

ALSO MANUFACTURERS OF

Rules, Levels, Planes, and Improved Carpenters' and Coachmakers' Tools, the Improved Sash Router, Patent Stop Chamfer Shave, Plumb Bobs, Trammel Heads, Steel Squares, Bench Stop, Boxwood Tool Pads, Thermometers, &c.

NEXT MEETING- TUESDAY FEBRUARY 13th

Mark Goodchild will be our next guest speaker. Those of you who saw Mark demonstrating his skill on Australia Day at the Barracks Museum will appreciate what a fascinating evening this will be. Don't miss it! Below I have reproduced some illustrations from the Commonwealth of Australia, Department of Labour and National Service, Industrial Training Division, April 1946 Technical Publication on PLASTERING.

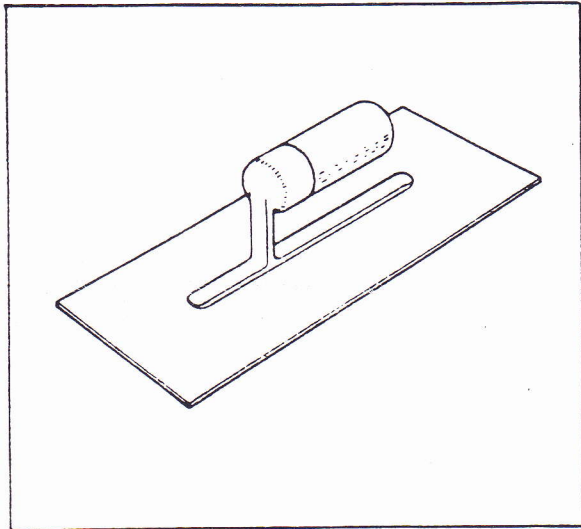

Laying Trowel.

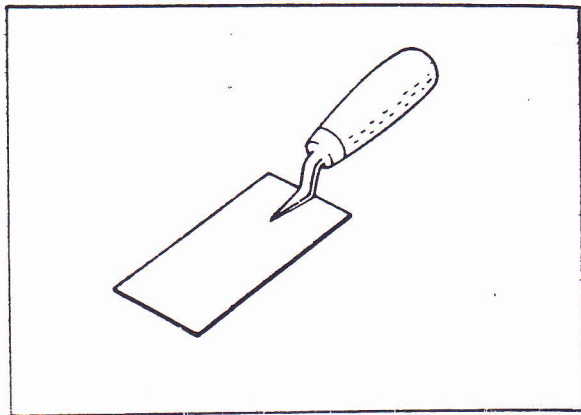

Margin Trowel.

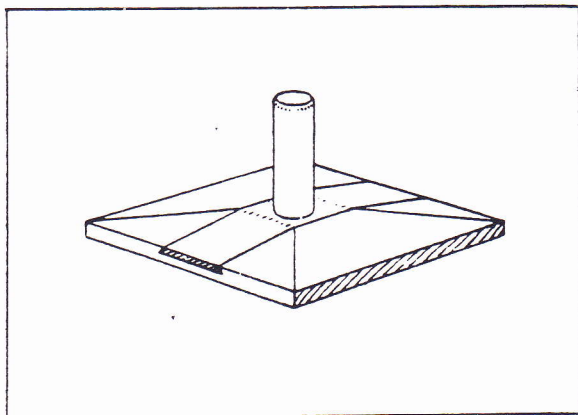

The Hawk

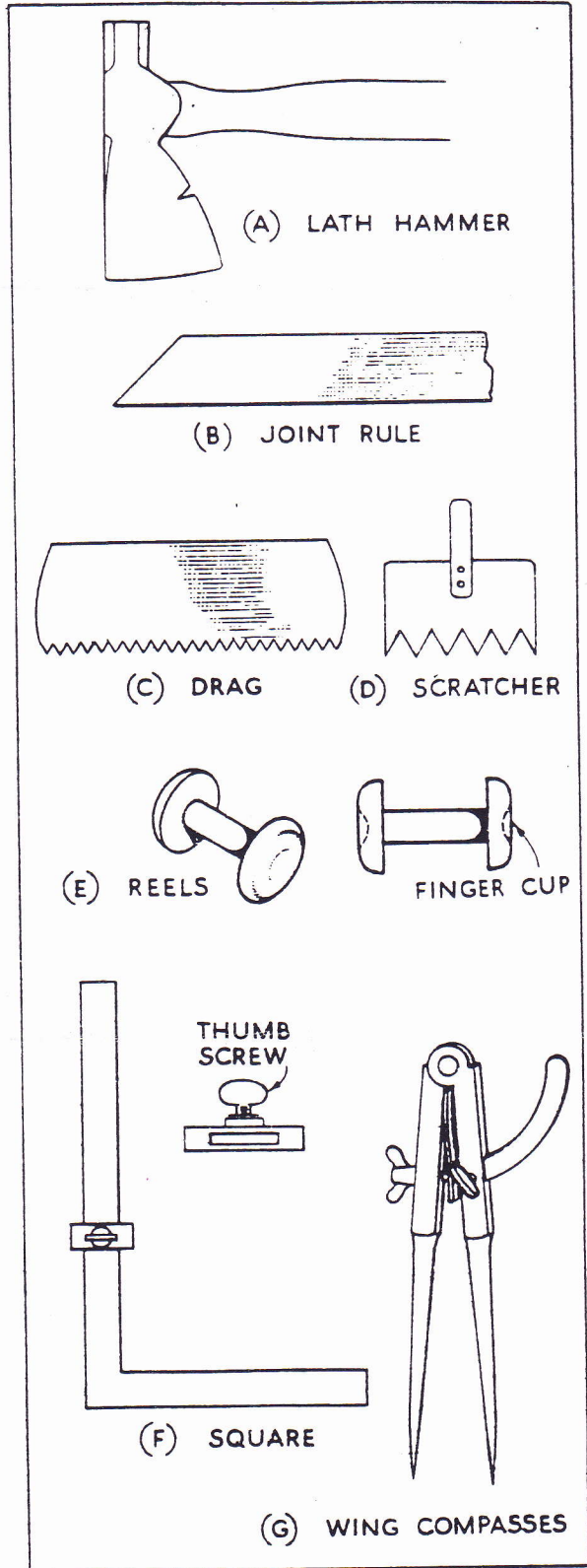

(A) LATH HAMMER

(B) JOINT RULE

(C) DRAG

(D) SCRATCHER

(E) REELS

FINGER CUP

THUMB SCREW

(F) SQUARE

(G) WING COMPASSES

Plasterers' Tools.

RESEARCHING TRADESMEN'S LINES

Members attempting to research ancestors or historic tradesmen should be aware of the existence of -

The Society of Australian Genealogists
Richmond Villa
Observatory Hill
Kent Street
Sydney 2000
Tel. 247 3953

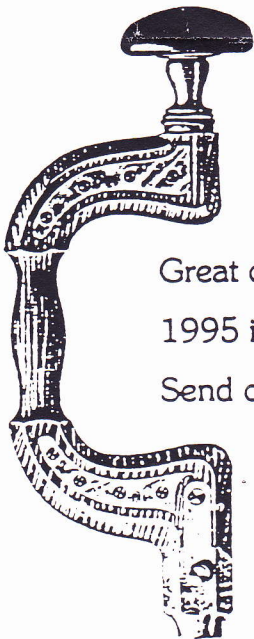
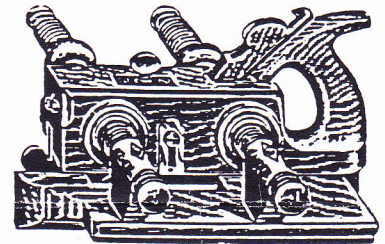
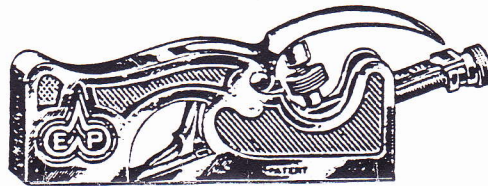

THE TOOL CHEST

Great choice of antique and old woodworking tools.

1995 illustrated catalogue of 250 new arrivals now available for \$5.00 only.

Send order and payment to:

The Tool Chest
Village Antiques
Warego Hwy, Withcott Q 4352
Phone: 076 30 3377

Woodies Books

Woodies Books. Suppliers of the Finest Woodworking Books Available.

Send self-addressed stamped business size envelope for Catalogue.

1289 Barkers Lodge Rd. Oakdale. 046-809494

Please note the new 'phone number.

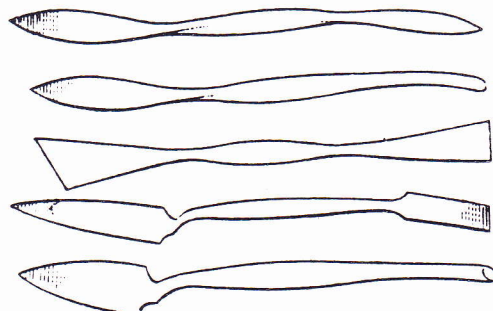
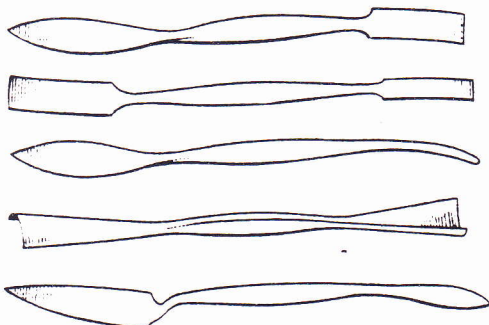

Plasterers' Small Tools.

**EXHIBITION HYDE PARK BARRACKS' MUSEUM
MACQUARIE STREET, SYDNEY**

Just a reminder that an exhibition of tools sponsored by TTTG is presenting a display at the Hyde Park Barracks' Museum.

The exhibition was organised by Historic Houses Trust staff member Gary Crockett assisted by Bob Crosbie, Ralph Hawkins and Fred Murrell.

TOOL SALE IN VICTORIA

The Hand Tool Preservation Association is holding a Tool Sale on 17th March at Glenferrie Primary School, 80 Manningham Road, Hawthorn Victoria. Sellers will set up at 7.30am and club members (including TTTG) are allowed in at 8.30am ahead of the General Public who gain entry at 9.30am. The Sale closes at 3.00pm. Entry costs \$2.50 per person and Sellers will be charged \$15 per Table. For further information contact Laurie Lewis on (03) 9578 3550 or Rod Thomas on (03) 9523 7178.

FOR SALE

**WOOD TURNING LATHE "CRAFTMASTER" 800mm
NO MOTOR, NO STAND. \$125**

**BROADAXE \$180
FROE \$80
MORTISE AXE \$120**

**CONTACT: BOB PEAK 02-525-2471
(or see Bob at the February TTTG meeting)**

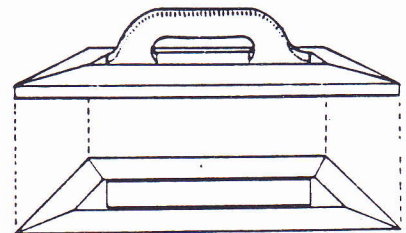

(A) MITRE FLOAT

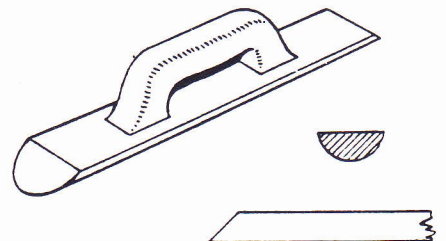

(B) HALF ROUND FLOAT

Floats for Solid Plastering.

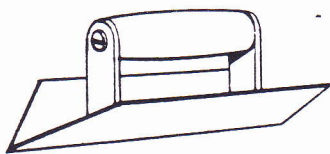

INTERNAL ANGLE

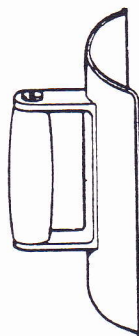

ROUND ANGLE

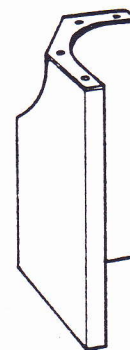

BOX ANGLE MOULD

Cove and Angle Tools for Solid Plastering.

REG EATON

Reg Eaton wishes to advise that he has the following tools for sale

Stanley No. 1 planes \$1500 - \$1600

Stanley No. 2 planes \$375 - \$400

Ultimatum & other brass framed braces from \$600

Postage and packing included.

Reg Eaton, 35 High Street, HEACHAM, King's Lynn, Norfolk, U.K. PE31 7DB
 Tel: 1485 570067
 Fax: 1485 571144

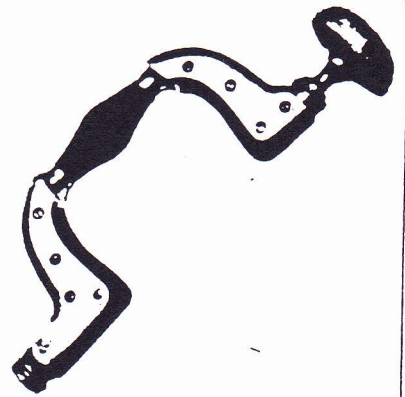

CHAS. E. SKINNER PTY. LTD.

WOODWORKING MACHINERY MERCHANTS, IMPORTERS AND ENGINEERS

17 COOLAWIN ROAD

NORTHBRIDGE, 2063

MACHINERY OVERHAULING & REPAIRS.
 To light woodworking machinery.
 Service work.
 Bearings renewed.

Cenurio heavy duty lathe
 4ft between centres
 18in swing, 3ph. 2hp. \$5,500

Phone/Fax.
 958-7336.
 Phone.
 958-5170.

Richardson pedestal drill
 Heavy duty floor model
 Price \$450 Recon. \$850

Richardson cyclone dust extactor
 3 Phase 2 Horse power \$250.00.

Jacob 12in table saw
 Single ph. 1hp \$695.

Woodfast lathe available
 Ring for details.



TEL (02) 326 1319
 FAX (02) 327 2770

MOBILE 018-042 155

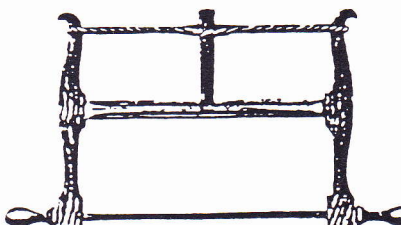

OLD WOOD WORKING TOOLS
 JOLYON WARWICK JAMES

SHOP 36 ANTIQUE CENTRE
 531 SOUTH DOWLING ST
 SURRY HILLS, SYDNEY

SPIERS, NORRIS
 STANLEY, RARITIES
 MARPLES ULTIMATUM ETC



The First Australian Tool Collectors Convention & Sale

Convention 23rd March 1996. Public Sale 24th March 1996
at Macquarie University Union, North Ryde, Sydney

Tool collectors from all over Australia and New Zealand will be meeting at The First Australian Tool Collectors Convention and Sale, to be held at Macquarie University Union, North Ryde Sydney. This event will give collectors an opportunity to talk, share ideas with other collectors, expand their knowledge and buy or sell antique and old tools, in a relaxed and pleasant setting.

The Convention will run from 10am-5pm on Saturday 23rd March 1996. Speakers will include Tony Murland, from The Tool Shop UK, Frank Ham - Secretary of HTPA from Victoria; Trevor Semmens from Tasmania - author of "Australian Planemakers" ; and George Ingham from ANU Institute of Arts - School of Woodwork, who will lead the discussions on old tools and aspects of tool collecting. There will be plenty of opportunities for participation in the discussions. The sales room will be open for convention delegates ONLY from 4-5pm. Lunch and refreshments will be included in the convention fee of \$65. Bookings are essential. A deposit of \$25 will reserve your place.

Dinner and a quality tool auction in the Court View restaurant at the Macquarie University Union will follow from 6.30-11.30pm. Bookings for the dinner/auction are also essential, cost \$65 head. Partners are most welcome. Entries of quality collectors tools are invited for the auction.

From 9am-4pm on Sunday 24th March, the sales room will be open to the public. Tony Murland, well known to Australian tool collectors through his International Tool Auctions, will have a comprehensive range of quality tools for sale. Also many local and interstate traders will be attending, and a huge variety of antique, collectible and useable tools and related books will be available. Entry to the sale will be \$5 single, \$3 concession, \$10 family. Food and refreshments will be available in pleasant surroundings within the sales room.

There will be ample parking at minimal cost, within the Macquarie University grounds, entry via Balaclava Road. Follow the signs to the sales room.

This gathering will provide an unprecedented opportunity to talk and meet with other tool collectors from around Australia and New Zealand and UK. We look forward to meeting you there.

For detailed trader, convention and auction information ph/fax 06-2886142
John & Priscilla McDonald or write to Tools of Trade PO Box 13 Duffy ACT 2611.

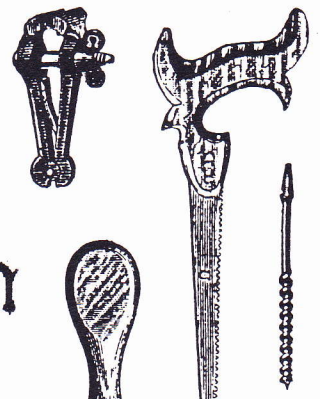
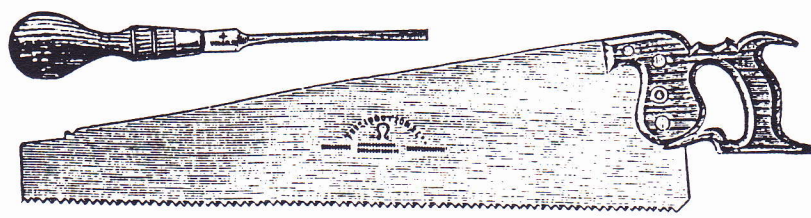
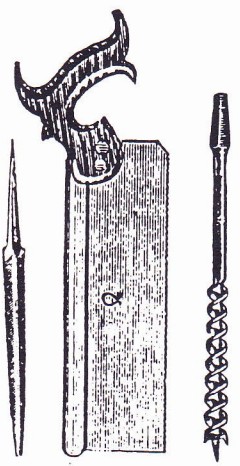

The First Australian Tool Collectors' Convention & Sale

will be held
at Macquarie University Union
North Ryde, Sydney

Saturday 23rd March 1996
Tool Collectors' Convention
10am-5pm Noted speakers on old tools
& tool collecting
6.30-11.30pm Dinner & Quality Tool
Auction (entries invited)
Convention bookings essential.

Sunday 24th March 1996
9am-4pm Public Sale
of Antique, Useable & Collectible Tools
Trader enquiries welcome.
Admission - \$5 single, \$3 concession, \$10 family
Entry to Macquarie University
car parks via Balaclava Road

For further information, to book for the
convention or reserve a trading table

phone/fax 06-2886142

John & Priscilla McDonald
Tools of Trade PO Box 13 Duffy ACT 2611

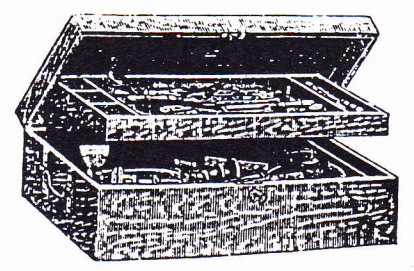
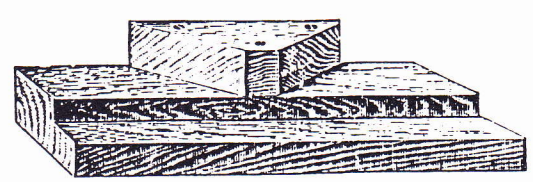
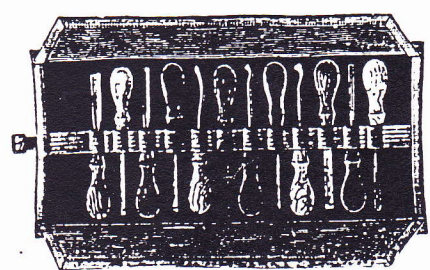
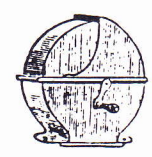
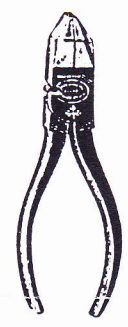
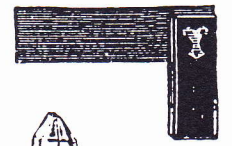
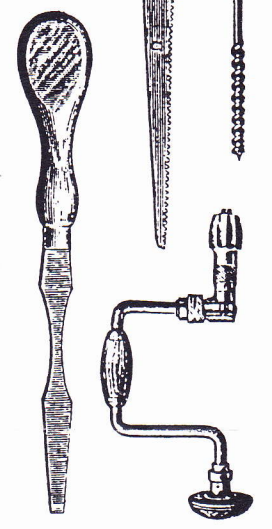
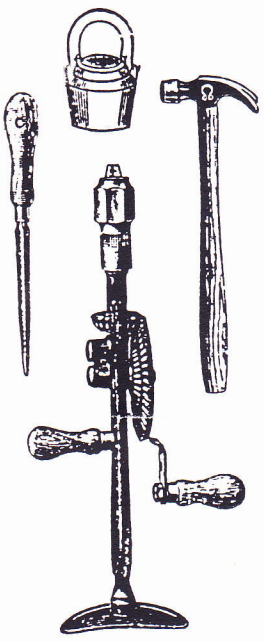
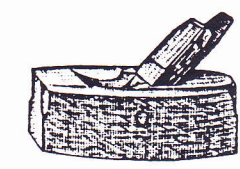
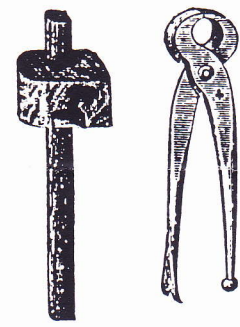

Listing of Stanley Tools for sale at the next 'Sydney Tool Sale & Swap'.
On display at Garrett Wade Sydney in 1996.

For sale on March 3rd .

Enquiries please 02-744-3458

3rd March
1996
SYDNEY
TOOL SALE & SWAP

#1 Try square Rosewood 6in.	G .	#60 Double cutter 'shave pat. June 19-1866	G
#2 Smooth plane Prelat Type 4	G+	#62 Low angle plane	G+
#3 " " " " 4	G-	#65 Chamfer 'shave	G
#4 " " " " 2	G	#67 Universal 'shave complete	G+
#5 Jack plane " " 3	G	#68 Rebate 'shave	G+
#6 Fore plane " " 4	G+	#70 Box scraper	G
#7 Jointer plane " " 2	G	#71 Router	G
#8 " " " " 4	G+	#71-1/2 Router	G
#A4 Smooth, handle décal. Pat. Apr-19-10	G++	#72 Double gauge	G
#A5 Aluminium Jack plane. " " " "	G	#72 Chamfer plane pat. April 21-85	G+
#A6 " " Fore " " " "	G	#72-1/2 " " " " "no bullnose or cutters	
#6 Bailey 'Victor' Fore plane.	G+	otherwise	G
#9-1/2 Type 2 Pat. Aug-31-58 Aug-6-67	G+	#79 Side rebate plane. Type 1	G+
#10-1/4 Bench rebate plane.	G+	#80 Scraper Type 1	G
#10-1/2 " " " "	G	#81 Scraper	G+
#11 Beltmakers plane	G+	#82 Scraper Pat. 1-29-07.	G
#12 Scraper sweetheart cutter	G+	#83 Scraper complete with wheel	G+
#12 Steel try square 6in.	G+	#85 Scraper plane. Pitted on one side,	G+
#12-1/2 Scraper, toothing cutter fitted.	G+	#88 Clapboard marker	G+
#13 Compass plane. Type 2 Prelat. solid wheel		#89 Clapboard gauge Pat Jan-31-88	G+
Bailey's pat. Aug 31-'58. Aug 6-'67.	G+	#90 Marking gauge in box	Fine
#14 Adj. try square 6in. Pat. 1-23-17.	G	#90 Rebate plane	G+
#15 Block plane Type 2 'B' Pat. on lat. lever 10-2-84		#92 Rebate plane. Current model in box .	
1-17-88. 7-24-88. 8-3-97. on body.	G+	#92 Butt & rebate gauge	G+
#18 Steel bevel 6in. Pat 7-14-08	G	#93 " " "	G+
#18 Steel bevel 8in. " "	G	#94 Rebate plane. Pat. on cutter	
#18 Steel bevel 10in. " "	G	plane rated as Fine, box as poor	
#18 Steel bevel 12in. " "	G	#95 Edge plane Boxed in wrapper.	Fine
#20 Compass plane	G+	#97 Chisel plane	G+
#26 Wood bottom Jack plane	G-	#98 Side rebate plane with depth stop.	G+
#28 " " Fore plane	G+	#99 " " " " in box. Plane	G+ box fair
#28 Cornering tool	G+	#100 Block plane	G+
#29 Wood bottom Fore plane	G+	#100TD Carpenter's 'take down' square	G+
#30 Angle divider	G+	#101 Block plane	G+
#34 Catalogue 1948	G	#102 " " "	fair
#36G Metallic plumb & level 9in. In original wrapper.		#103 " " "	G+
With instructions P-26M-8-44.	New in box	#104 Steel body & wood parts only.	Fine but incl.
#39 Dado plane 1/2in.	G	#110 Block plane	G
#39 Dado plane 5/8in.	G+	#112 Scraper plane with toothing cutter	New in box.
#40 Scrub plane	G+	#113 Compass plane side wheel	G+
#41 Miller's pat plow plane. Type 4. Fillester missing		#113 " " pat. 9-8-03	G+
fence has brazed repair at rear	G-	#129 Fore plane	G
#42 Saw set	G+	#140 Block plane	G+
#42W Saw set	Fine	#141 Bull nose plow plane. SW. No fillester, only one	
#42X Saw set in box with instructions		cutter, needs a good clean but should make G+	
dated 15m-11-44	Fine	#144 Corner rounding plane 1/4in.	G+
#43 Miller's pat. plow 8 cutters. Type 6	Fine	#148 Match plane	Fine
#45 Combination plane pat.	G	#193A Fibre board cutter plane in box	Fine
#46 " " body & fence only	G	#200 Chisel & cutter grinder. Pat 12-10-12	G+
#46 Pocket level pat 6-23-96	G	#202 Bench dog	G+
#50 " " with cutters	G+	#203 Bench bracket	G+
#51 & 52 Shoot board & plane	G++	#212 Scraper plane	G++
#53 Adjustable throat 'shave	G+	#239 has been repainted otherwise	G+
#54 Plow & rebate plane nickel plated	G	#386 Jointer gauge (fence)	G+
#54 " " " japanned	G-	#444 Dovetail plane in box complete.	G+
#55 Hollow 'shave	G	#720 Socket chisel 2in.	G+
#56 Cooper's 'shave	G+	#902 Tool box only, no tools.	G
#57 Core box plane 1 set sides	G+	#00 Rosewood level (sweetheart logo).	G+

THE FINE TOOL JOURNAL CONDITION CLASSIFICATION SYSTEM FOR ANTIQUE HAND TOOLS

	Category	Useable	Finish	Wear	Repair	Rust	Misc.
N	New	totally	100%	none	none	none	+ original packing
F	Fine	totally	90-100%	minimal	none	trace	nicks/scratches
G+	Good+	yes	75-90%	normal	minor/none	light	minor chips
G	Good	yes	50-75%	moderate	minor	light	chips OK
G-	Good-	probably	30-50%	heavy	correct	moderate	
Fr	Fair	no	0-30%	excessive	major	heavy	
P	Poor	no	none	excessive	damaged	heavy	