

T T T G



Newsletter 41.

June 1998.

The Traditional Tools Group Inc.

"My uncle—carrying a box on his back."

TTTG Inc.

THE TRADITIONAL TOOLS GROUP (Inc.)

TTTG NEWSLETTER NO. 41.
June 1998.

<u>Contents.</u>	<u>Page.</u>
Next Meeting.	1
Editor's Notes.	2
Letters to the Editor.	3
Terry Butcher's Tasmanian News.	4
Collectors Page.	5 - 7
TTTG News.	8
TATHS News.	9
"Stewart Spiers" Planes.	10-12
Geometrical Joinery without Geometry. (The Cylinder Method.)	13-14
Tools used in the Cylinder Method.	15
Book Review.	16
Research Notes.	17-18
Directory.	19
Advertisements.	19
Advertisement Request Form.	20

Cover: "My uncle-carrying a box on his back."
From Woodworker June 1966.
The Coffin maker, C.H.Hayward.

(c) Copyright. 1998.

Opinions expressed are those of the contributor.

EDITOR'S NOTES.

At last the new format TTTG newsletter!
Newsletter No 7 established the pattern for the newsletter with an illustration on the front page.

Newsletter No 8 increased the number of pages in the newsletter. The editor faced resistance with objections such as; "who wants a newsletter" and "we will soon run out of ideas". Eventually the newsletter was accepted as a necessary means of communication for TTTG.

The editor was dissatisfied with the format of the newsletter. The Committee resolved earlier this year to improve the quality of the newsletter.

The new format is the first step in developing a superior journal dedicated to traditional technology.

The anticipation, and hope, is that this improved format will encourage members to submit articles for publication.

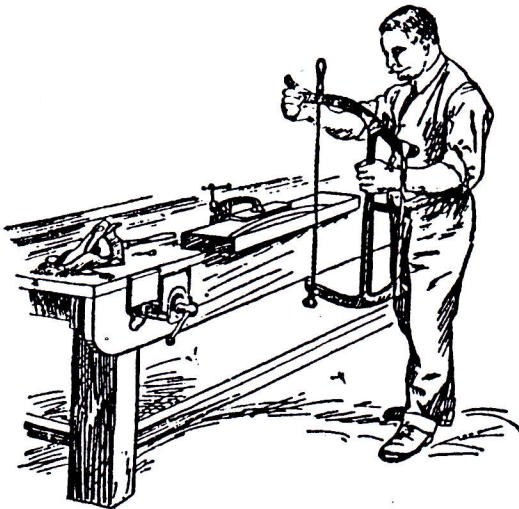

2.

—THE CHAIRMAKER'S (OR BETTY) SAW.

LETTERS TO THE EDITOR.

The editor has received a letter from Rod Thomas regarding a copy of "The Hardware Journal" 1954 which was given to Rod by the TTTG Committee.

As an indication of the value of such Australian publications an extract from Rod's letter is reproduced.

"I have not digested all the material as yet, however I have already added a number of new names to the list and added more information to several existing entries.

I had an inquiry from a member recently about Tiger brand saws and was unable to help him at the time. He now has a copy of the mark, the maker and a circa date of manufacture.

Although not a "tool" the Whittingslowe washing machine was of interest as I have a lot of information on this inventor and manufacturer. His pressed metal block plane is well known, his pen knife and openers also, but his kitchen paraphernalia and other gadgets maybe not as well. To my knowledge he made a total of 33 patent applications many of which lapsed, but also 7 Registered Designs all over a fairly short period of time.

This type of publication tends to contain a wealth of information for our research purposes, hopefully we will have access to additional material as time passes."

(Rod Thomas 29th March 1998)

Rod is compiling a data base of Australian manufacturers. In this he has the full support of TTTG. Any information received concerning local manufacturers will be forwarded to Rod Thomas..

The TTTG Library is seeking copies of Australian publications. Material loaned to TTTG will be photocopied and made available to TTTG members and researchers.

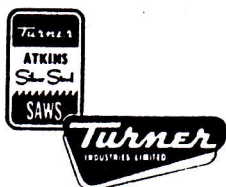

Terry Butcher's Tasmanian News.

I have just finished reading Newsletter #40 which came today. I loved the articles on War -time tools. No wonder Britain won the war -- with tools like that who could have had a chance against the might of British tradesmanship!

Seriously folks they were really very interesting. I wonder if anybody actually made and used them. If they did turn up at a tool sale or whatever they would be easily recognisable being pretty unique in their design .

Such tools would make a wonderful chapter in Trevor Semmens' book. Well I've got two very interesting metal planes, a Smoother and a Jack, probably made during the war or just after.

In the general opinion of the Melbourne "mob" they would have been made in the Ipswich Railway Workshops. Australian made, no doubt about it, may be copied from Mc Connel planes.

Thank you also for your comments on the proposed Tasmanian chapter of TTTG. I will shortly be writing to those collectors whose names I have collected. I guess it will take about a year before we get off the ground.

Thank you also for the copy of the Carter catalogue and of the leaflet for Carter #54.

Editor.

Terry's "**Report from Tasmania**" dated 15 April '98 is a detailed account of the HTPAA Tool Conference and Sale. A typed copy of this paper is available from the TTTG Library.

4.

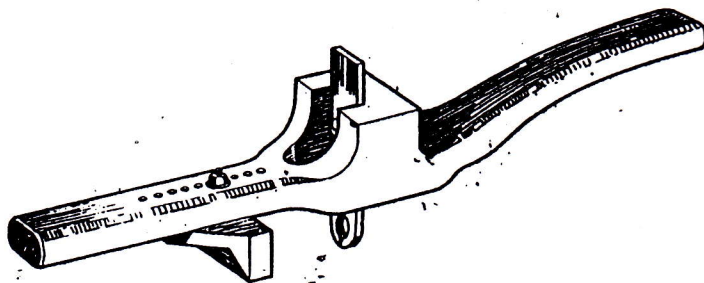

COLLECTOR'S PAGE.

Extracts and illustrations from; Ellis, George
"Modern Practical Stairbuilding and Handrailing
Part 1. Chapter 20 Apparatus and Tools.....

The Handrailer's Scratch Stock.(Fig. 7 and 8, Pl. XLIII).

"This is an indispensable tool which is not yet obtainable from the tool shops; consequently it varies in form with the taste of the maker. The design shown is that of the author's own tool. It consists of a straight cylindrical stock, $1\frac{3}{4}$ in. in diameter, the off end rounded, the near end shaped to a ball handle; any close grained hardwood will do; my own is of black walnut. The stock is made in two halves which, after slotting for the knives or "scratches", are screwed together and shaped. A $\frac{3}{4}$ in. hole is bored through at right angles, to receive the adjustable fence, which should be of some very hard close-grained wood, such as Lignum vitae or boxwood-the former is the better, in consequence of its greasy nature. It is advisable to have this stem turned in a lathe first, then to make the hole to fit it. The scratches are really moulding cutters made of any required shape by filing or grinding pieces of thin steel, such as a broken table knife blade, or piece of tenon saw blade, to the required contour and fixing them as shown in the stock." They are worked around the wreath piece, to finish the moulding, after it has been roughed out with gouges or thumb planes. The scratches should be filed square across, and their edges turned with a bradawl similarly to a scraper's edge. The stock is worked rather slowly backwards and forwards keeping the cutter quite upright, until an absolutely perfect surface is obtained, the operation being in the nature of scraping rather than planing; therefore the tool must be worked down gradually. The scratches are frequently made double-ended, so that they can be reversed, as shown in dotted lines in Fig. 7, Pl. XLIII., also the stock can be double-ended, as indicated in dotted lines, with an extra hole for the stem. This is useful when more than one wreath of similar section is to be moulded, as their successive sections can be worked without disturbing the setting of the other scratch.

COLLECTOR'S PAGE.

The Adjustable Quirk Router.(Figs. 10 and 11 Pl. XLIII).

is, in its specialised form, a home-made tool. There are varieties, both in wood and iron, to be met with in the tool shops, but the former are intended for ordinary woodworker's use, and do not exactly meet the handrailer's requirements, whilst the latter, though stronger than wood, do not, at least in the author's opinion, work so sweetly as the home-made article.

The form shown is somewhat elaborate; many workmen are satisfied with simply a square stick with the rough edges filed off and a wood screw driven through the fence. Certainly a good workman will accomplish wonders with makeshift tools, but, as other things being equal, the better the tool the better the work, and the author always had a penchant for making his own tools, so he offers his own design for those who care to follow it. The quirk cutter, which is a piece of tempered steel about 3 ins. long and $\frac{3}{4}$ in. wide, of various thicknesses, is shown in two views, Fig. 12. The ordinary shop-made article is always flat or straight across the face, but cutters work much easier if slightly curved in section, which can be done by softening the cutter in a gas jet, then bending it in a steel vice between two hardwood blocks to the required curvature, afterwards re-tempering it- a little job that any blacksmith will do. The author did his own, but the description of the process would be rather lengthy. The stock is $1\frac{1}{2}$ in. square, about 12 ins. long, with small handles turned at the ends; the cutter fits tightly in the mortice, which must be quite upright and is wedged as shown. The sliding fence, lips over the stock, is reversible, one side is rounded slightly, the other straight. It is fixed in any desired position with a thumb-screw. An ordinary "plough stop" screw answers the purpose. A small slotted plate is sunk in the top side, in which the screw works; the amount of adjustment is about an inch, as shown by the dotted lines. The underside of the stock should be slightly rounded, because the tool must have a rocking motion when worked, because the V part of the cutter, which is in advance of the chisel edge, has to be scored-in before the cut is made.

Collectors Page.
Illustrations.



*Elevations of
a Scratch Cutter.*

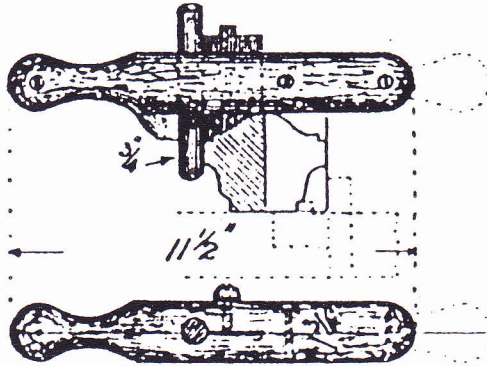

*Side and Top Views of
a Handrailers Scratch Stock.*

*An Adjustable
Quirk Router.*

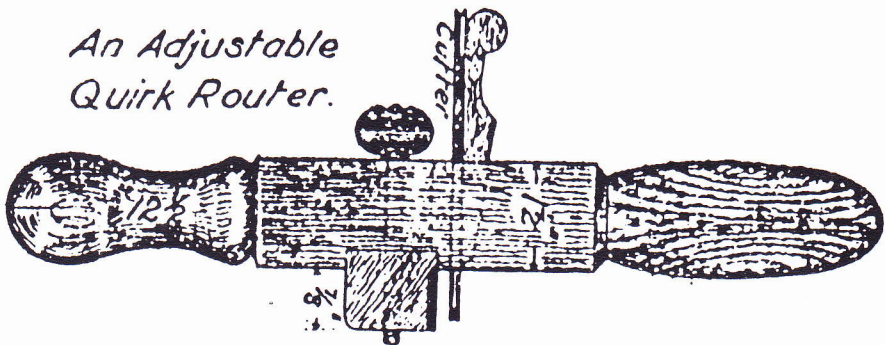

Side View.

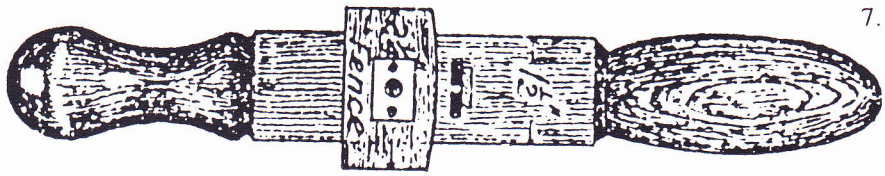

Bottom View.

TTTG NEWS.

The Committee intends to develop a series of activities for TTTG members.

Plane restoration classes.

We believe there is a demand for workshop classes in the use of traditional woodworking tools.

At this stage we need an indication of interest.

A one day workshop would cost about \$40 and be limited to 10 participants.

Topics covered would include;

- reconditioning old edge tools.
- sharpening and using edge tools.
- correct traditional techniques.

Tools included would be planes and chisels.

Special Issue.

TTTG Working with Wood Show 1998.

The Editorial Committee will produce a special issue of the newsletter for sale at the 1998 Timber and Working with Wood Show.

The issue will be a compilation of articles from previous TTTG newsletters.

The format will be similar to issues numbers 1-40.

The Special Issue will be on sale at the show for the nominal sum of \$2.50

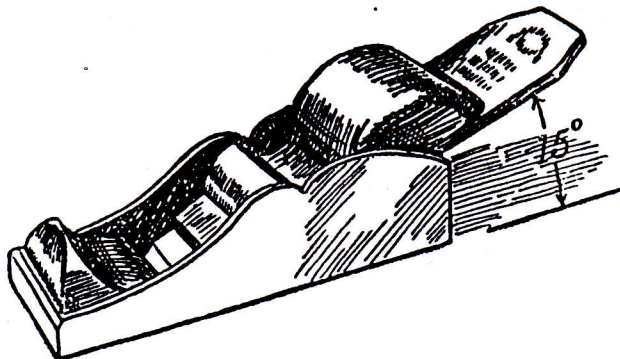

8.

—CHARIOT PLANE.

TATHS News.

Taths Newsletter 60.

This issue contains several items of interest.

Articles include;

“Reconstructing a Roman Hammer”,

“Pioneers in Planemaking”,

“Coachmaker’s Plough”.

There is a review of Mike Hendrikson’s book

“**The Secrets of Wheelwrighting- Tyres**”.

The reviewer begins with these words;

“In my opinion this book is a modern day version of “The Wheelwright Shop” by George Sturt, I am unable to fault it.”

As the reviewer is Bert Bailey the comments carry some authority.

When I reviewed Mike’s book he accused me of being over generous!

I look forward to Mike’s next book.

The newsletter can be borrowed from the TTTG Library.

TTTG Library Donations.

Bob Crosbie has donated the following items.

Photocopy : Hacksaw Blades. their selection use and care.
Turner Industries Limited. 1950s ?

Semmens, Trevor Australian Woodworking Planemakers.
Second Edition



“Spiers”, “Empire”, “Plane-O-Ayr” Planes.

Bob Crosbie

“By the 1920s, like other makers, the firm (Spiers) had been forced to add a range of cheaper cast planes,.....

” British Planemakers 3rd Ed. page 413.

Spiers developed three types of cast iron planes by the 1920s;

- a) Malleable cast iron versions of the dovetailed planes.
- b) Cast iron planes based on the Bailey patents, The “Empire” Plane.
- c) A cast iron design unique to Spiers, The “Plane-O-Ayr”.

Each of these cast iron planes was for a different consumer.

Do these cast planes reflect a decline in the quality of the Spiers’ product or are they rather an expansion of the Spiers’ range of planes?

Spiers had experience with cast planes before the 1920s. The title page of the 1909 catalogue describes Spiers’ planes as being made of Wrought Iron, Steel and Gun Metal. This catalogue does list cast planes. These are all Gun Metal options; No. 8 Shoulder, No.10 Chariot and No.11 Bull-nosed Rabbet. Cast Gun Metal lever caps were the stock lever cap for all planes except the rabbet, shoulder and bull-nosed rabbet planes.

The title page of the Spiers’ catalogue speculatively dated to circa 1930 describes Spiers’ planes as being made of Mild Steel, Malleable Iron, Gun Metal and Iron. All the cast iron planes in the catalogue are described as being malleable.

Malleable cast iron is a quality cast iron product. Spiers was attempting to capture a wider market by offering less expensive good quality planes as well as the traditional dovetailed planes. The majority of the malleable cast iron planes in the 1930 catalogue are, like the Gun Metal planes, versions of the standard dovetailed planes.

Malleable cast iron was not offered for a number of plane types. This reflects Spiers’ emphasis on quality. The No. 4 Steel Rabbet with two irons, the No. 11 Bull-nosed Rabbet and the No. 12 Coopers’ Plane or “Plucker” are not offered in malleable cast iron. Is it because such planes in malleable cast iron would be likely to fracture if dropped?

10.

STEWART SPIERS

Iron Plane Manufacturers

Even with the "Empire" Plane there is an emphasis on quality. This plane is described as "undoubtedly the cheapest superior Plane in the market." The "Empire" Plane was Warranted Unbreakable. Given the light castings in the Stanley planes of the 1920s can we dismiss Spiers' Empire plane as a poor quality product?

In 1909 the three Spiers sisters trading as Stewart Spiers and the Stewart Spiers' foreman, William McNaught, applied for a patent titled "Improvements in Planes for Wood-working Purposes." The application was accepted in March 1910.

The patent drawings are identical in essential details to the Spiers planes marketed as "Plane-O-Ayr". The known Spiers' catalogues do not include the "Plane-O-Ayr". The orthodox view is that the "Plane-O-Ayr" planes were manufactured in the 1930s. "Plane-O-Ayr" planes are seen as inferior planes, a last attempt by Spiers to stay in business.

Recently I acquired a "Plane-O-Ayr" smoothing plane in rusted condition but with the original blade. As I cleaned the rust and the paint dabs off the plane I quickly realised it was not a cheap and nasty product.

I sharpened and set the blade and took the first shaving. This was gold leaf thin, as good as any dovetailed wood infilled plane. But the real surprise was the lightness of the plane. The "Plane-O-Ayr" performs as well as the best Spiers dovetailed plane without the fatigue producing weight of the wood stuffed plane.

Examination of a "Plane-O-Ayr" will reveal the superior quality of the foundry work. This is a design based on a vast experience in metal plane manufacture. The inherent design fault is the means used to secure the handle. Is this the reason the "Plane-O-Ayr failed?

Consider the client it was designed for, a tradesman requiring the performance of a Spiers' dovetailed plane but unable to afford one. The light weight of the Plane-O-Ayr, the superior performance and the reduced cost would have made it an attractive plane.

Stewart Spiers relied on a discerning clientele. Scots tradesmen carried the reputation of Spiers around the world. The firm ultimately failed due to a circumstances beyond its control. This was the almost total collapse of the economy of the British Isles in the 1930s.

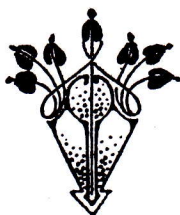

Illustrations.
Stewart Spiers.

Spiers' "Empire" Planes.



British Made throughout.

No. 14.

For Description, see page 17.

Adjustable Bed and Cutting Iron.
Extra Heavy Cutting Iron.
Works perfectly on Hard or Soft Woods.

9½ in. X 2 in. Plane Iron	Steel
9½ in. X 2¼ in. „	15/-
15¾ in. X 2¼ in. „	16/-
	20/-

WARRANTED UNBREAKABLE.

Geometrical Joinery without Geometry. The Cylinder Method.

Bob Crosbie.

Traditional joinery involves numerous complex geometrical constructions. Staircases immediately come to mind. Less obvious are "circle on circle doors" and "splayed jamb linings".

Old joinery text books provide the geometrical solutions to setting out such types of joinery. These texts provided apprentices with the worked examples necessary to pass trade theory exams.

How were such jobs tackled in the workshop? Geometry could be used and no doubt frequently was used.

There are however non geometrical methods which were once in common use. These non geometrical methods are rarely to be found in the text books.

Joinery manuals written this century reinforce two aspects; trade geometry theory and trade geometry practice.

The theory comes down to the use of "lines" and the practice to the application of the "Steel Square". Both lines and the square depend on a theoretical understanding of geometry.

The older non geometrical method provided solutions to geometrical problems without requiring any knowledge of geometrical theory. The key to understanding this method is provided by George Ellis.

In "Modern Practical Stairbuilding and Handrailing", 1932, Ellis devotes a chapter to the older non geometrical method of making handrails. (Pt. 2 Ch. 28 "The Cylinder method of Making Wreaths".)

Ellis observes that the Cylinder Method was going out of use when he entered the trade. This dates the method to the period before the 1860's. No doubt the method was in use in small workshops well after this date.



Sketch of Cylinder Set-out.



*Sketch of Plank
cut and marked for squaring.*

The Cylinder Method is a direct means of establishing the shape of the wreath. A cylinder is constructed which fits inside the plan view of the handrail.

By drawing the elevation of the stairs and handrail on the outside circumference of the cylinder the pitch of the handrail is established. The stuff for the wreath is then cut and fitted to the cylinder. Ellis describes the advantages of this method and the practical means of achieving the task.

There are wider applications of the Cylinder Method.

Cylinders were also used to "stave" shaped jamb linings. The cylinder was constructed to fit the elevation view inside the door or window opening.

The radius, for circular head, or radii, for elliptical head, was taken from the architect's plan, checked against the completed masonry.

For a "circle on circle" jamb head the plan shape had to be developed. This could be done by "lines", geometry, or by the older direct method. A card pattern could be traced directly from the masonry. The pattern was cut to shape and laid on the back of the staved jamb.

Public building doors "bow", shaped in plan, and "circle on circle", shaped in plan and elevation, could be constructed on a cylinder. Rails were fitted to the cylinder to give the plan shape and the elevation shape was transferred onto the rail. The elevation shape could be scribed by use of the falling compasses.

These older methods were seen by the text book writers as being unscientific. However they are an alternative means of solving problems.

In an age of sheet materials it is easy to draw a geometric construction to a reasonable scale. When every wide surface had be planed before a drawing could be made more direct methods must have had great appeal!

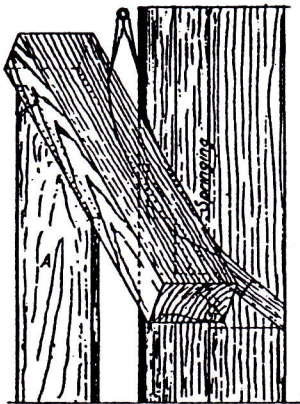

Elevation of Cylinder, Scribing the Plank.

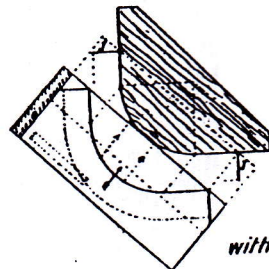

Plan of Cylinder with Plank applied.

Tools used in the Cylinder Method.

“Nowadays this bevelling would be done by means of a band saw, but at the time referred to it was done with a **large two-handed frame saw** having a blade 1½ ins. wide.

If properly marked and cut, very little cleaning up was required, but also very often correction had to be made with a **handrailer’s compass plane**, a tool now seldom seen. This was a kind of short Jack-plane with a rounded sole, made to fit the job in hand, and was traversed across the edge until the plank fitted the cylinder closely, when it would lie as shown in the dotted outline in Fig. 4. Next the plank was gauged to a width by means of a **grasshopper gauge**, shown in Ill. 25 and the wreath cut out to this line; it was then applied to the cylinder in the original position and a pencil run down its face to mark the outline on the cylinder; any required number of points were then ticked off on the face, also on the cylinder, and the wreath removed, when the distances between the edge line of the wreath and the edges of the rail section taken in the compasses were pricked off on the inside of the wreath as shown in Fig 6. The outline of the rail was then drawn through these points.” (see Plate 32).

Extract from:

Ellis, George "Modern Practical Stairbuilding and Handrailing"

Part 2 Chapter 38

The Cylinder Method of Making Wreaths.

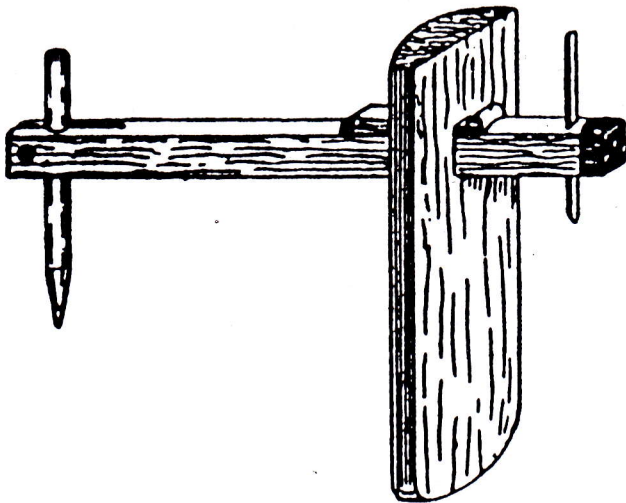

15.

—GRASSHOPPER GAUGE.

Book Review.

Trevor Semmens,
“Australian Woodworking Planemakers
Second Edition”.

This is an improved and enlarged version of the first edition. The author has undertaken further research into Australian planemakers.

The book is arranged in alphabetical order of each known, or in some cases possible, plane maker. The biographical synopsis for each entry is enhanced by clear photographs of planes.

A few entries are speculative. For example it is unlikely some of the retailers listed ever produced planes. The only labour they put into the planes they sold was to stamp their Trademark on the planes' toe.

The section on Carter planes is very comprehensive. As fate would have it a Carter catalogue has surfaced. The author was apparently unaware of this catalogue.

The discussion of Falcon and Pope gives a good overview of both makers. More material will emerge about Pope and Falcon.

There is a brief entry for Turner. This is the company which requires more research. Turner manufactured a wide range of products to very high quality standards.

The editor has written to the author and passed on some information concerning a number of Sydney retailers and has invited him to write an article for this newsletter.

As more information is uncovered about local manufacturers it is inevitable that a third edition of Australian Woodworking Planemakers will be necessary.

For the moment every TTTG member needs a copy of the Second Edition. With post and packing the book costs a mere \$16.50. Fill in the order form and send your cheque direct to the author.

A copy of Australian Woodworking Planemakers is available from the TTTG Library.

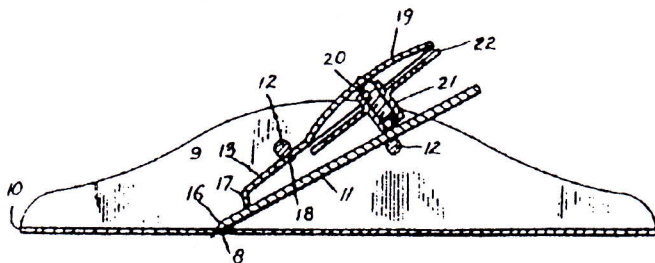

RESEARCH NOTES.

Stewart Spiers Planes.

The **Plane-O-Ayr** design is a development of the cast plane. The Plane-O-Ayr was designed in 1909 as an attempt to produce a quality affordable plane for the tradesman.

The Plane-O-Ayr is plane technology reduced to its essentials. All unnecessary detail has been eliminated. The result is a plane which produces a perfect cut with the minimum of effort.

The secret of this planes' performance is the total rigidity of the thick blade combined with the lightness and balance of the body.

The means used to secure the heel handle to the casting is as ingenious as it is unsuccessful.

The Plane-O-Ayr patent should be seen as a development in plane making technology.

The Empire plane was an attempt to capture some of the market for Stanley planes. In marketing the Empire Spiers' emphasised its superior quality.

In reality few post World War 1 tradesman could afford Spiers' planes. The reputation of the Spiers' plane allowed the firm to continue production until the affects of the depression were too great to resist.

Spiers' emphasis on quality and the assumption of discernible purchasers combined with a world depression made the firms' chances of commercial success increasingly marginal by the 1930s.

The Plane-O-Ayr requires further research. Was it marketed in 1910? Does any reader know of any Spiers' catalogue or advertisements additional to those reprinted by Ken Roberts? The author has noted two profiles of Plane-O-Ayr smoothing plane.

SPIERS

PLANES

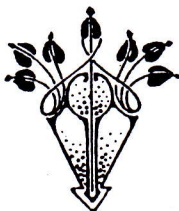

Illustrations. "Plane-O-Ayr" Patent.

[This Drawing is a reproduction of the Original on a reduced scale.]

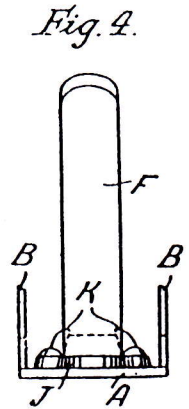
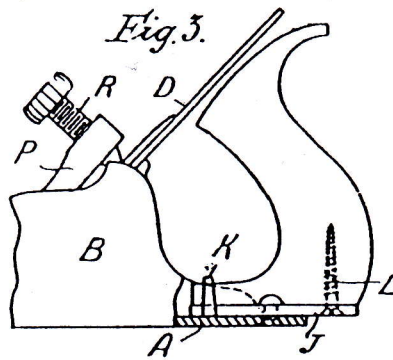
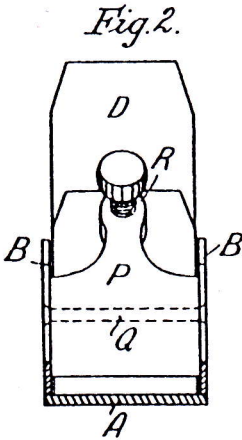
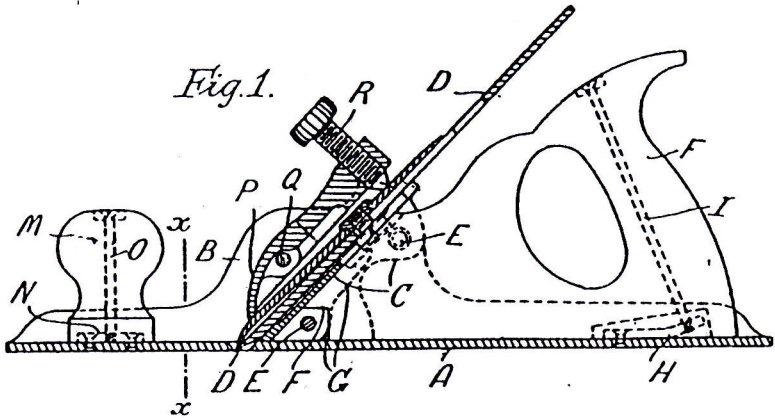

Directory.

The Traditional Tools Group Inc. TTTG
P.O. Box 240 Grosvenor Place
Sydney N.S.W. 1220

Tools and Trades History Society. (TATHS.)
The Administrator TATHS
60 Swanley Lane,
Swanley, Kent, BR8 7JG United Kingdom.

Hand Tool Preservation Association Australia. Inc. (HTPAA.)
P.O. Box 1163 Carlton Victoria 3053

Hand Tool Preservation Society of Western Australia. (HTPSWA)
8 Belham Street, Bayswater Western Australia 6053

CLASSIFIED ADVERTISEMENTS.

WANTED.

Copies of the following books;
Wells and Hopper
"Modern Cabinetwork "
1909,
George Ellis
"Modern Practical Joinery"
June 1902
Woodworker Annuals.
Condition and price to The editor TTTG.
(or phone 0298697487)

Advertisement Request.

Newsletter Sub-Committee
TTTG Inc. P.O. Box 240
Grosvenor Place, Sydney N.S.W. 1220

Name;

Address:

Suburb/City:

Country/Postcode:

Phone/Fax

Tick type of Advertisement For Sale Wanted

Please place the following in the TTTG newsletter;

(Print advertisement below)

RATES:

Commercial advertisements;

50c per line,

Quarter page \$10, Half page \$15, Full page \$20

First advertisement is free.

(Non-commercial advertisements free.)

Terms:

book three placements to receive first placement free.

Layout and artwork to be supplied by advertiser.

Advertisers will be invoiced after first placement.

Signature:

date:

Australian Woodworking Planemakers

An invaluable resource for all those interested in collecting woodworking planes.

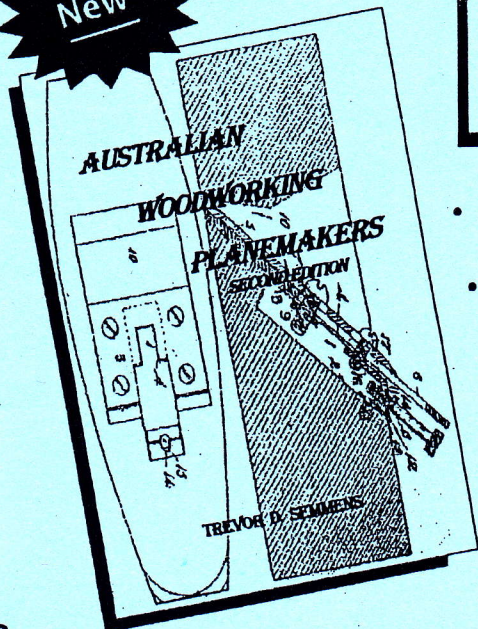

**Second Edition
Now Available
Order Today!**

- An invaluable addition to your 'British' and 'American' planemakers!
- An inventory of all known Australian plane manufacturers.
- Liberally illustrated with photos and drawings.
- Updates and greatly expands on 'Australian Planemakers', published in 1993.
- 48 pages, (210mm x 297mm) with attractive soft cover.
- Great value at only **\$ 15**



Please send me: Australian Woodworking Planemakers

Name:

Address Postcode

Order Form

No of copies	Unit Price	Add postage and handling	Total
		\$1.50 each book (within Australia)	\$
		\$2.50 each book (overseas)	\$

To order, post this form to:
Trevor D Semmens,
19 Loinah Rd, Montagu Bay, Tasmania 7018
Telephone: (03) 6244 2586

Total payment is enclosed for: \$

The Traditional Tools Group

